

Strong and durable, wheeled pop-up case for safe transportation of graphics.

features & benefits

- Manufactured from tough moulded polyethylene (MDPE)
- Wheels & handle for easy transportation
- 0.1m³ carry capacity
- Case can be locked using padlocks (not supplied)
- Can serve as a display counter - supporting a graphic wrap
- Two leonardo's can be joined together to serve as an oval shaped display counter supporting a graphic wrap

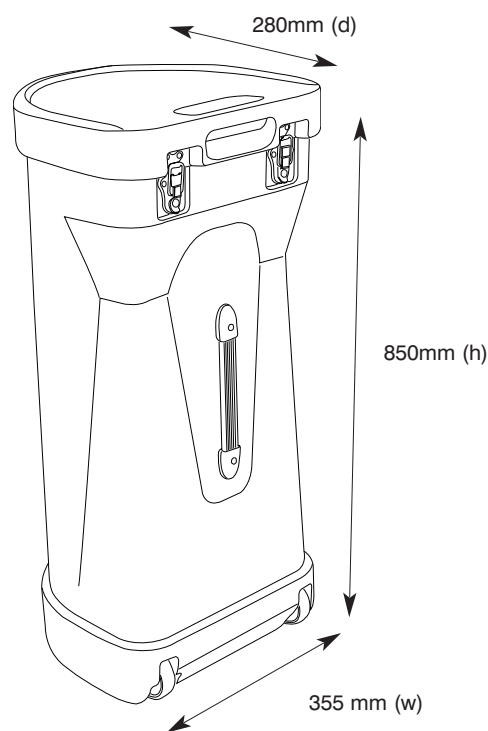

All sizes are approximate

hardware specifications

Internal size (h) x (w) x (d):
850mm (h) x 355mm (w) x 280mm (d)

Weight (when empty):
5kg

wrap specifications

Graphic/Fabric Wrap dimensions (h) x (w):

Single: 700mm x 1230mm & overlap

Double: 700mm x 1860mm & overlap

All sizes are approximate